



XR-600

OWNERS MANUAL

GENERAL DESCRIPTION

The new XR-600 represents our latest effort to combine professional features previously found only in separate mixer /equalizer /power amp components into a single compact and rugged package. The redesign of the XR-600 utilizes the latest advances in semiconductor technology and the overall circuitry has been designed and optimized by use of the latest computer-aided design techniques. This unit's improved specifications have been made possible by a thorough and complete design effort resulting in all new circuitry from the input jack through to the speaker output.

The XR-600 features six independent input channels and includes a separate "pre" monitor send, active shelving type high and low equalization, and a "post" effects send on **each** channel. Master level controls are provided for the main, monitor, and reverb return. A full nine-band graphic equalizer has been built into the system and utilizes the most contemporary active filter circuitry available. Additional flexibility is provided by the XR-600's patch panel, enabling this versatile unit to be used in conjunction with an extremely wide range of auxiliary equipment.

The newly re-engineered 210-Watt RMS (4 Ohms) power amplifier features our exclusive DDT® ("Distortion Detection Technique") compression circuitry that electronically senses the onset of clipping and automatically activates the compression circuit to minimize distortion in the power amp. The use of this DDT® compression circuit effectively increases the apparent headroom available, thus utilizing every precious watt of power available. This compression feature allows the XR-600 to quite effectively compete with units having considerably more RMS power.

The power amp of the XR-600 utilizes eight high-voltage, high-speed T0-3 power devices bolted to a massive heatsink. The internal power supply consists of a very large power (mains) transformer featuring a grain oriented silicon steel core and a high degree of magnetic shielding to minimize extraneous hum fields. Silicon rectifiers connected in a full wave bridge feed power to large electrolytic filter banks and provide considerably more music power than the 210 Watts RMS (4 Ohms) power rating would indicate.

Overall, the XR-600 brings professional performance together in an extremely versatile and compact package, offering features and specifications formerly available only with separate components in a single portable package.

WARNING: To prevent electrical shock or fire hazard, do not expose this appliance to rain or moisture.

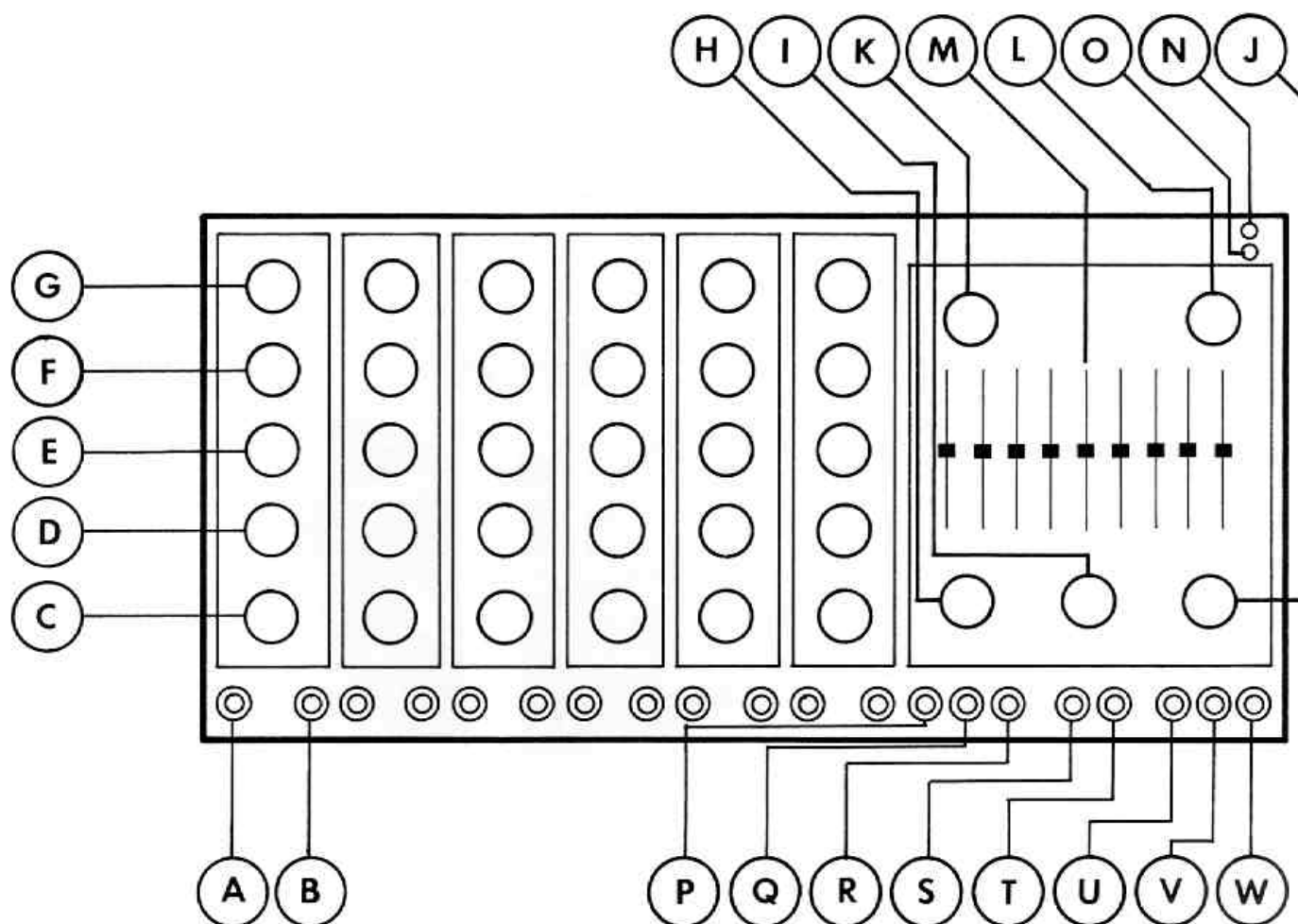

FRONT PANEL

INPUT JACKS (A) AND (B)

Each channel of the XR-600 is equipped with two input jacks which are connected in a unique circuit that allows a wide range of inputs to be handled. When only one microphone is used, the "A" input jack is more sensitive than the "B" input jack. This high and low gain feature enables optimum microphone matching. If a high output microphone is overloading the sensitive "A" input, simply reconnect this mike into the low gain "B" jack. When two inputs are used in each channel, the input circuit automatically balances to equalize the gain in both A and B jacks. This simple, but effective, switching system gives the user much greater flexibility in choice of input sensitivities and overload protection.

CHANNEL CONTROLS

Each of the XR-600's six independent channels contain five controls: Level, Monitor, Effects and High and Low Equalization.

CHANNEL LEVEL CONTROL (C)

This control varies the level of the input preamplifier. This input preamp is designed around a variable negative feedback approach and provides optimum dynamic range as well as extremely low noise operation. This control is used to set the level of the respective channels to achieve the **main mix**.

CHANNEL MONITOR CONTROL (D)

The channel monitor control is a totally **independent** level adjustment used for deriving the proper monitor mix. It is important that the user be aware that this channel monitor send is totally independent from all other channel controls and feeds directly into the monitor buss whose output is determined by the master monitor control (I).

CHANNEL EQUALIZATION CONTROLS

The channel equalization controls are of the active "shelving" type and provide 15 dB of boost or cut in their respective frequency ranges. These equalization controls are extremely effective and will allow the user to achieve almost any blend of high's and low's with proper adjustment. Since these EQ controls are capable of a 30 dB range, care should be taken to properly utilize their capabilities. Excessive boosting of low's can cause "muffled" or "boomy" sounds, as well as tending to prematurely overload the power amp because of excessive low frequency power requirements. Overboosting the high's will tend to cause a "strident" or "screechy" tonality, as well as tending to emphasize residual preamp noise and susceptibility to acoustic feedback. Care should be observed when using excessive cut in either frequency range since excessive cutting may degrade the dynamic range capabilities of the input preamp and create poor tonality.

These channel equalization controls have been provided to achieve tonal balance, as well as feedback control in the individual channels for the main mix only. All experimentation should begin with these controls set in the flat "0" (straight up or 12:00) position. Use of the individual channel controls in conjunction with the master graphic equalizer is vital to provide the user with optimum equalization.

CHANNEL LOW EQUALIZATION CONTROL (E)

The low equalization control determines whether the low frequencies will be boosted or cut. Boost occurs in the clockwise settings, while cut occurs in the counterclockwise settings. Flat response is obtained in the "0" vertical position.

CHANNEL HIGH EQUALIZATION CONTROL (F)

The high equalization control determines whether the high frequencies will be boosted or cut. Boost occurs in the clockwise settings, while cut occurs in the counterclockwise settings. Flat response is obtained in the "0" or vertical position.

CHANNEL EFFECTS CONTROL (G)

The channel effects send control adjusts the signal level applied to the effects mix buss which feeds the internal reverberation system, as well as the effects output on the patch panel. The overall settings of the channel effects send controls determine the amount of reverb drive, as well as the signal output level available from the effects output jack. It is important to note that the effects send control is a "post" type adjustment which is located in the circuit **after** the channel gain and equalization controls. The user should be aware that use of the internal reverberation system can only occur when the channel gain, the channel effects send, the master effects level, the master reverb return and the master gain controls are all properly adjusted.

MASTER SECTION

The XR-600 master section contains overall main level control, the master monitor control, the master effects control, the reverb return (to master) control and the master auxiliary level control, as well as a nine-band graphic equalizer and patch panel. As the name implies, the master controls operate as the final control element for their respective mixing busses and the master graphic EQ determines the final overall equalization.

MAIN LEVEL CONTROL (H)

The MAIN level control adjusts the gain of the main mixing buss and determines the level at the main line output jack (P), as well as determining the signal level applied to the input of the graphic equalizer/power amplifier. It is generally good practice to operate the main level control somewhere in the middle of its operating range to allow maximum flexibility in adjusting overall levels, i.e., it is poor practice to run the individual channel gains way up and the main control way down since this effectively negates flexibility afforded by the main control, as well as limits dynamic range.

MASTER MONITOR LEVEL CONTROL (I)

The master monitor control adjusts the gain of the monitor mixing buss and determines the level of the signal available from the monitor output jack (Q). The operation of this control and its independent channel sends is identical to that of the main with the exception that its output is applied to the monitor line output jack instead of the main output jack.

MASTER EFFECTS CONTROL (J)

The master effects control sets the signal level applied to the internal reverberation system and the effects output jack (R). It is important to note that no reverb effect **or** effects signal will result unless suitable settings of the master effects control are used. The action of this control is similar to both the main and monitor master controls and may be used accordingly to determine the overall output level of the effects mix buss.

MASTER REVERB RETURN CONTROL (K)

The master reverb return control determines the amount of delayed signal (reverberation) that is mixed back into the main mix buss. The action of this control (K) is defeated by use of a remote switch being plugged into the footswitch jack (U) located on the patch panel. It is important to note that no reverberation will occur unless the internal delay line is being fed signal from the channel effects send controls. The master-reverb return control **does not** affect the level available from the effects output jack (R) located on the patch panel.

MASTER AUXILIARY LEVEL CONTROL (L)

The auxiliary level control determines the gain of the auxiliary input channel. This channel may be considered a seventh input to the master mixing buss and may be used for a wide variety of purposes. This auxiliary input channel is unequaled, except by the 9-band graphic, and features high input impedance and wide dynamic range to enable maximum compatibility with auxiliary units. It is important to realize that the auxiliary input channel feeds the main mixing buss and the auxiliary level control determines the amount of auxiliary signal mixed into the main mix.

GRAPHIC EQUALIZER (M)

The nine-band equalizer is of the latest active type and exhibits performance comparable to that found in the finest commercial equipment. The graphic equalizer is located in the circuit just before the internal 210-Watt (4 Ohms) power amplifier and provides a very versatile and professional equalization of the overall system. Because of the flexibility built into the XR-600, several different modes of operation are possible.

NORMAL MODE

Under normal operating conditions (no patch connections), the graphic equalizer/power amplifier is connected through the graphic input switching jack to the main output which is the signal derived from the main mixing buss and controlled by the master gain control.

MONITOR OPERATION

The graphic equalizer and internal power amp may be used to power a monitor system, when not powering the main, by simply patching from the monitor output to the graphic input using a short shielded patch cable. When this patch is accomplished, the signal from the main mixing buss is available **only** at the main output jack (P) on the patch panel to be used in conjunction with external power amps, equalizers, or other accessories.

MASTER EQUALIZATION

The master graphic equalizer is designed to provide room equalization, effective feedback control, and overall system tone control. It is important to note that there are no firm operating instructions that will result in the ideal EQ for each and every set of operating conditions. Experimentation with adequate understanding of the graphic equalizer is necessary to achieve optimum results. No amount of equalization will correct an acoustically bad room/mike/speaker arrangement or completely correct the response curve of a poor loudspeaker.

Please make sure that the power amplifier has adequate headroom to handle any boost that may be incurred. If you boost 100 Hz by 3 dB, your power requirement will double. As an example, if your normal performing level requires 100 Watts, the power required after a 3 dB equalization boost will be 200 Watts.

You should always begin operation with the equalizers in the "0" or center position. It is wise to avoid excessive cutting of large segments of the audio passband since this tends to reduce the dynamic range of the system. Also, it is better to raise the level control rather than to use the majority of the equalizers in the boost position since better overall signal-to-noise ratio will result. As with any equalizer, careful experimentation and a little common sense will yield the best result.

FEEDBACK CONTROL

A graphic equalizer can be used to great advantage for feedback suppression. The whole point of equalization is to obtain the highest system gain before feedback. In essence, this requires a speaker system to be as flat as possible. The following procedure is given as a guide only! Use common sense and take your time when attempting the equalization process and your chances of obtaining the desired results will be very good.

Adjust all channel equalization and the graphic equalizer controls for an indicated flat response, and slowly bring up the level by use of the

channel or master level controls until the system starts to go into feedback. Then very slowly adjust each section of the graphic equalizer until you find the one that has the most effect on the feedback. Return all other sections to the flat position, and bring up the gain until the system again goes into feedback. Repeat the procedure and equalize out the second and third feedback modes and more if necessary. **WARNING!** You should never have to cut more than 6 to 9 dB under normal conditions. If more cut is necessary, check for proper phasing of the speaker system and microphone positioning. One improperly phased speaker can cause unending feedback problems. Do not expect to obtain a system that is completely free of feedback. A simple 1-octave graphic equalizer can only do so much. In short, don't expect miracles....

PILOT LED (N)

The pilot LED indicates when the electrical supply is switched on and is actually delivering power to the amplifier.

"DDT®" COMPRESSION WITH LED INDICATOR (O)

The XR-600 is a compact and powerful system which features a 210-Watt RMS power amplifier (4 Ohms) with a new type of dynamic compression. The compression effect enables us to maximize the performance of the amp/speaker combination. We have determined through much research that the compression circuitry should prevent the amp/speaker combination from running out of headroom (clipping) and should be as simple to operate as possible to avoid undue complication for the user. Because of the dynamics of a typical sound system, it is quite common to activate the compression as indicated by the limit LED (light emitting diode) (O) virtually constantly during a performance. This is what the compressor was designed to do; i.e., to maximize the dynamics available from the amp within its power output capabilities. We have not included other compression controls since we have designed an exclusive "Distortion Detection Technique" (DDT®) circuit that senses conditions that might cause overload, and compression is activated **only** when clipping is imminent. This technique effectively utilizes every precious watt available from the power amplifier.

XR-600 PATCH PANEL

The patch panel of the XR-600 has been designed to allow use of auxiliary accessories, mixers, power amps, etc., in conjunction with this unit.

MAIN OUTPUT (P)

The main output provides output from the main mixing buss. This output is of relatively low impedance and is capable of over 4 Volts RMS into 600 Ohms or over 8 Volts RMS into higher load impedances. The output level is determined by the gain and equalization settings of the individual channels, as well as the main level control (H) in the master section.

MONITOR OUTPUT (Q)

The monitor output provides a signal for an external monitor system and is a relatively low output impedance capable of over 4 Volts into 600 Ohms or over 8 Volts into higher load impedances. The level is controlled by settings of the individual channel monitor sends as well as the master monitor level control (I).

EFFECTS OUTPUT (R)

The effects output has been designed to deliver output signal from the effects buss for driving various line level devices. Caution should be observed when using accessory devices designed for guitar level (100 mV) to avoid overloading these devices with the relatively high output signal level available from the effects out. Overall signal level is determined by the setting of the various effects send controls of the respective channels, as well as the master effects control (J). This output is of relatively low impedance and is capable of approximately 4 Volts into 600 Ohms or 8 Volts into higher load impedances.

GRAPHIC INPUT (S)

The graphic input jack provides a means to allow patching into the internal graphic equalizer / power amp. The jack is of the switching type that normally picks up the signal from the main output jack (P). When a plug is inserted into the graphic input, the circuit path is broken and this input may now be plugged into other devices or any of the output jacks of the XR-600. The graphic input provides much greater flexibility in allowing the internal graphic / power amp to be utilized as a monitor amp or for any other purpose the user may deem necessary. Its input impedance is approximately 50K Ohms at approximately 1 Volt signal level for full power output at the speaker jacks.

GRAPHIC OUT (T)

The graphic output provides the capability to "isolate" the entire graphic equalizer. Because we have provided patch points at the input **and** at the output of the graphic, total flexibility is achieved. The graphic may be patched "in line" with any of the outputs of the XR-600 and the line inputs of any external devices.

FOOTSWITCH (U)

The footswitch jack provides a way to accommodate the optional remote reverb cutoff pedal. This footswitch jack is conventional and should present no operational problems.

AUXILIARY INPUT (V)

The auxiliary input provides access to the main mixing buss for patching in signals from the external devices such as delay lines or extra mixing channels. Its input impedance is 220K Ohms and is designed for low to medium level signals of up to 2 Volt RMS.

POWER AMP INPUT (W)

The power amp input has been provided to allow the XR-600's internal power amplifier to be patched into any output of the XR-600 or to any signal source capable of delivering 1.5 Volts RMS into 10K Ohms. The power amp input is normally connected through a switching jack to the graphic output (T). When a jack is inserted into the power amp input, the switching contact that normally connects to the graphic out is broken, thus isolating the graphic equalizer and making the power amp's input available to signals from other devices or any of the output jacks of the XR-600.

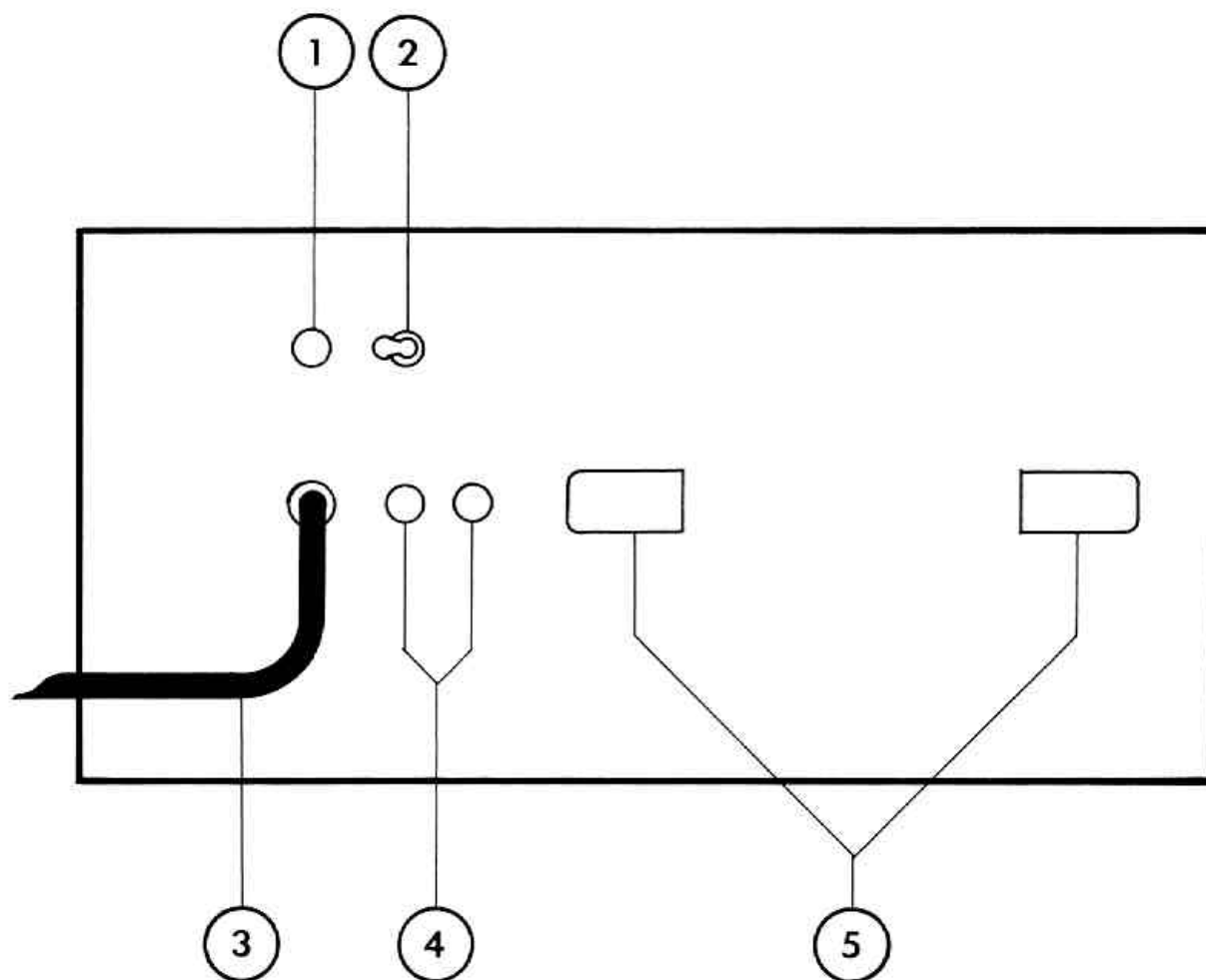

REAR PANEL

FUSE (1)

The fuse is located within the cap of the fuseholder. It is necessary that the fuse be replaced with the proper type and value fuse if it should fail in order to avoid damage to the equipment and to prevent voiding the warranty. If your unit repeatedly blows fuses, it should be taken to a qualified service center for repair.

POWER SWITCH (2)

On domestic units, the power switch is of the three-position type with the center position being "OFF." This switch has two "ON" positions, one of which is used to ground the amplifier properly. One of the "ON" positions will yield the lowest amount of residual hum or "popping" when the instrument is touched and this is the position that should be used.

On export models, we utilize a simple on/off switch that does not have multiple "ON" positions since the grounding (earthing) conditions in most other countries are positively made through standard tamper-proof plug-in systems.

LINE CORD (3)

For your safety, we have incorporated a three-wire line (mains) cable with proper grounding facilities. It is not advisable to remove the ground pin under any circumstances. If it is necessary to use the amp in a two-pin plug system without proper grounding facilities, suitable grounding adaptors should be used. Much less noise and greatly reduced shock hazard exists when the unit is operated with the proper grounded receptacles.

SPEAKER OUTPUTS (4)

The speaker output jacks are of the standard $\frac{1}{4}$ " type. Both the output jacks are wired in parallel and either or both may be used when connecting your speaker system. The 400B module has been optimized for a 4-Ohm load but has adequate performance to drive loads both above and below the recommended 4-Ohm impedance. Extreme care should be used when operating a unit at below 4 Ohms since lower load impedances tend to overload the power amplifier and may cause premature activation of the power amp's short circuit protection system and/or thermal fault protection circuitry. Because of the unique design of the compressor, the circuit will still minimize clipping regardless of load values.

LINE (MAINS) CORD RETAINER (5)

We have provided two large molded line cord retainers on the rear panel to allow storage of the mains cable for travel. In operation, the cable should be completely unwrapped to allow maximum heat dissipation from the rear panel/heatsink.

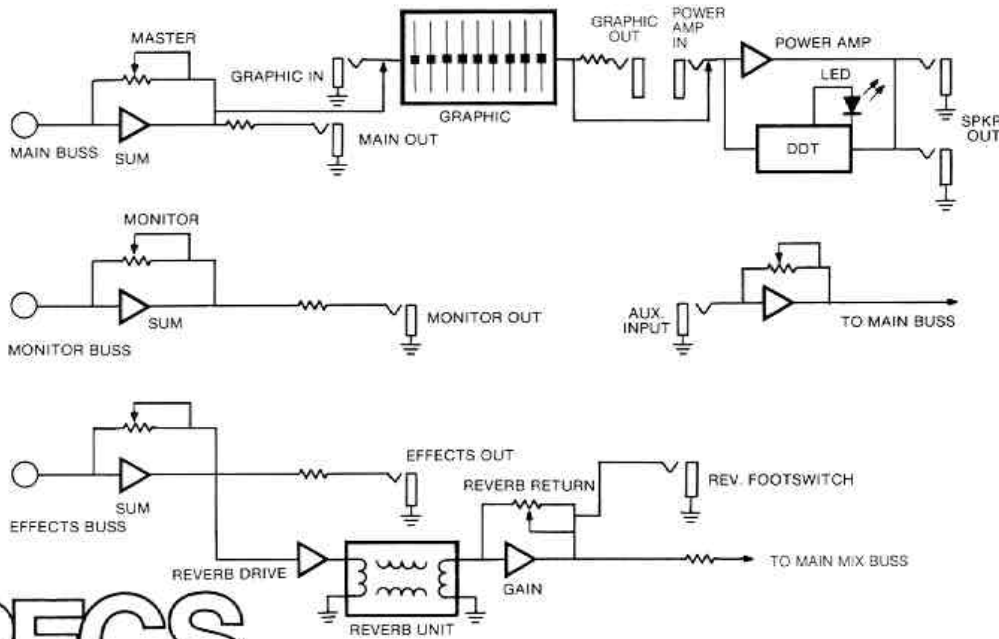
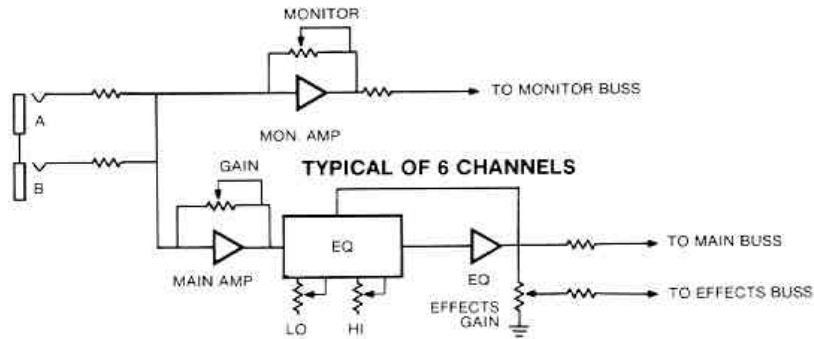

SPECS

CHANNELS:

6

INPUTS:

12 High Z, 6 being high gain, 6 being padded (-6 dB); Graphic input; Auxiliary input; Power Amp Input

SENSITIVITY:

Master & Channel Gain @ Vertical (12:00) setting; All EQ flat, 100 mV into High Gain Input for 200 W RMS @ speaker output into 4 Ohms, 48 dB Gain

MAXIMUM DYNAMIC RANGE:

3 V RMS @ Jack A

6 V RMS @ Jack B

MAXIMUM GAIN:

66 dB with channel Gain full CW

80 dB with channel Gain and Main Level full CW

INPUT IMPEDANCE:

220K Ohms (Jack A)

44K Ohms (Jack B)

SIGNAL-TO-NOISE RATIO:

Master @ 12:00, All EQ flat, 20 Hz - 20 kHz unweighted;

1 channel Gain @ 12:00, shorted input, 78 dB

1 channel Gain @ 12:00, 22K Ohm source, 76 dB

All channel Gains @ 12:00, 22K Ohms source, 72 dB

CHANNEL EQUALIZATION:

+15 dB @ 80 Hz & 8 kHz, Shelving

Characteristic

MASTER GRAPHIC EQUALIZATION:

+15 dB @ 50 Hz, 100 Hz, 200 Hz, 400 Hz, 800 Hz, 1.5 kHz, 3 kHz, 6 kHz and 12 kHz, Peak/Notch Characteristic, Average "Q" of 1.8

TOTAL SYSTEM FREQUENCY RESPONSE:

+2 dB, 40 Hz - 25 kHz, All EQ flat

LINE OUTPUTS:

Main, Monitor, Effects, and Graphic

MAXIMUM OUTPUT:

8 V RMS into 10K Ohms (+18 dBV) or

4 V RMS into 600 Ohms (+14 dBM)

POWER AMP SPECIFICATIONS

RATED POWER:

210 W RMS into 4 Ohms load

POWER @ CLIPPING:

(1% THD @ 1 kHz, 120 V VAC line)

Typically:

130 W RMS into 8 Ohms

225 W RMS into 4 Ohms

280 W RMS into 2 Ohms

FREQUENCY RESPONSE:

+0, -1 dB, 10 Hz - 30 kHz, 200 W RMS into 4 Ohms

TOTAL HARMONIC DISTORTION:

Less than 0.1%, 200 mW to 200 W RMS, 20 Hz

- 10 kHz, 4 Ohms, Typically below .05%

INTERMODULATION DISTORTION:

Less than 0.1%, 200 mW to 100 W RMS, 60 Hz

- 5 kHz, 4 Ohms, Typically below .04%

PEAVEY ELECTRONICS CORP.



711 A Street/Meridian, MS. 39301

© 1979

PRINTED IN U.S.A.